

FLAT CIRCULAR CUP WITH VULCANISED SUPPORT

These cups are recommended for handling very heavy loads both vertically and horizontally. They are vulcanised onto a steel support and have a labyrinth graved face made in the same compound as the cup. The support is provided with four steel pins with self-locking nuts for guiding the cups and fastening them to the machine, as well as with a threaded sleeve for vacuum connection. Moreover, these cups are provided with four springs to cushion its impact with the load to be lifted. These cups are available in the three standard compounds.

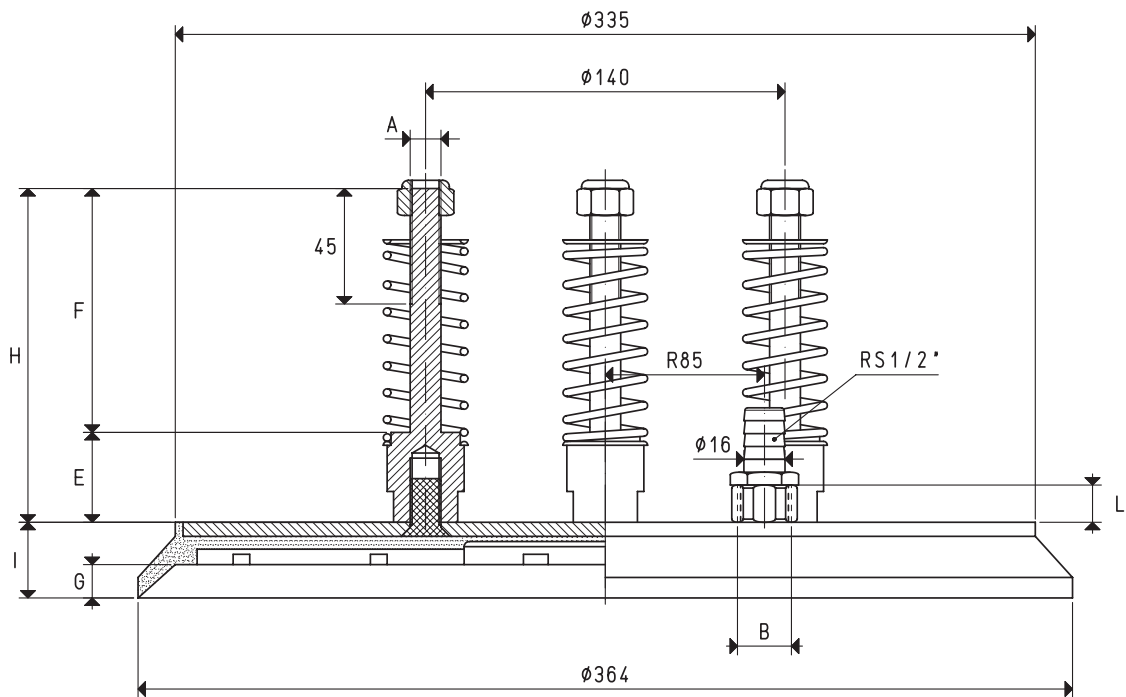

3D drawings available at www.vuototecnica.net

CUPS WITH VULCANISED SUPPORT

Art.	Force Kg	A Ø	B Ø	E	F	G	H	I	L	Support material	Weight Kg
08 360 10 *	254.3	M12	G1/2"	35	95	13	130	29	16	steel	4.75

* Complete the code indicating the compound: A= oil-resistant rubber; N= natural para rubber; S= silicon